

# WONCHANG

## Installation and Operating Manual

### VCX SERIES VACUUM PUMP MODEL 1005



# **INSTALLATION & OPERATING MANUAL**

## **VCX-SERIES CLAW VACUUM PUMPS**

### **VCX 1005**

Please read the manual before operating the vacuum pump.

## **TABLE OF CONTENTS**

### **1.0 INSTALLATION**

- 1.1 General description
- 1.2 Unpacking
- 1.3 Location
- 1.4 Power Requirements
- 1.5 Pressure Connections
- 1.6 Oil Filling on Gear box

### **2.0 SAFETY**

- 2.1 General Notices
- 2.2 Warning Label and explanation
- 2.3 Location of Labels

### **3.0 OPERATION**

- 3.1 Start-up
- 3.2 Stopping the pump
- 3.3 Ambient operating conditions

### **4.0 MAINTENANCE**

- 4.1 Pump Lube Oil (level / type & quantity / change)
- 4.2 Maintenance Chart

### **5.0 PROBLEM SOLVING**

### **6.0 TECHNICAL DATA**

- 6.1 Options

# INSTALLATION AND OPERATING MANUAL

This manual is written to cover following contact-less operating claw type vacuum pump. The model number is stamped into the nameplate with serial number: VCX 1005

***Please identify the model number and serial number when ordering parts.***

## 1.0 INSTALLATION

### 1.1 General description

The VCX vacuum pump is dry and contactless machines, enclosed in acoustic sound shield and designed to have cooling air passed through the sound shield by fan. The warm air is exhausted to the below compartment where silencer is located. The VCX is constructed in modular construction consisting of two compartments: pumping and gear chambers separated by using labyrinth seals. In the pump chamber, as two rotary claws rotate in opposite direction, the air sucked in, compressed and discharged under pressure. In the gear chamber (box), two gears for synchronizing of claws rotation will be located with oil lubrication. The pumps are directly driven by a flanged motor via a coupling. Configured with two silencers suitable for compact installation space. The 4" aluminum check valve for anti suck back and inlet filter (flanged) can be installed separately. Ideally suited to use with Frequency Controlled Drives for energy saving.

### 1.2 Unpacking and Storage

Inspect the box and vacuum pump carefully for any signs of damage incurred in transit. Since all pumps are ordinarily shipped F. O. B. from our factory or regional warehouse, such damage is the normal responsibility of the carrier and should be reported to them.

The inlet and exhaust of the pump are covered with plastic caps to prevent dirt and other foreign substances from entering to it . Leave these caps in place until you are ready to pipe the compressor to your equipment.

The pump should be stored in a dry environment with normal air humidity (RH 0~80%, -10C to 60C), not for more than 6 months. After that period, the pump conditions should be checked and cared with replacement of moisture absorbent if necessary.

### 1.3 Location

Install the pump in a horizontal position on a level surface so that it can be evenly supported on its rubber feet.

Leave 20 ~ 25 cm of access around the compressor to allow proper cooling. Also, adequate ventilation must be provided for the cooling for the compressor and motor.

Allow access to the oil sight glass in order to inspect the oil level regularly, and the oil fill and oil drain port for easy service.

## 1.4 Power Requirements

A schematic diagram for the electrical motor terminal connections is located in the junction box of the motor or on the motor nameplate. Typical wirings for Three Phase Motors are as below:

### Wiring Scheme- Three Phase Motor

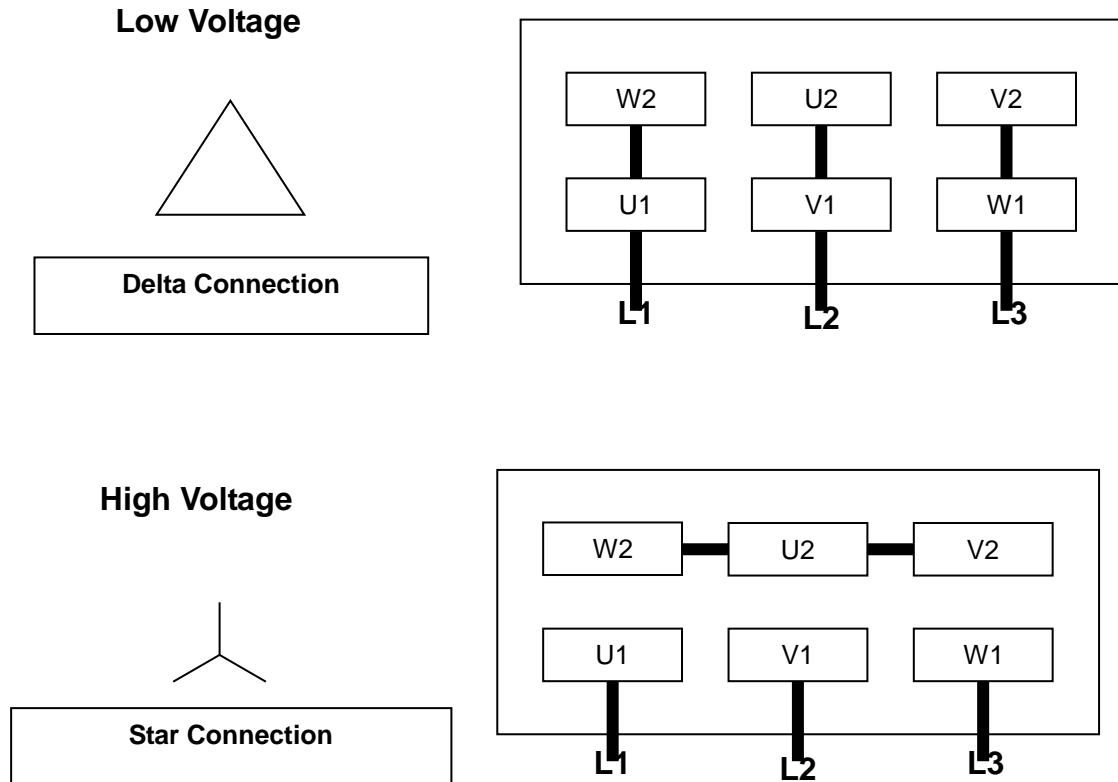

The motor must be connected according to the electrical codes through a fused switch in order to protect the motor against electrical or mechanical overload conditions. The overload of the motor starter must be set at a level equal to the full load motor current listed on the motor nameplate.

If the pump is supplied with a motor starter, it is preset at the factory according to customer specifications.

It is advisable to check that these settings are in line with the voltage at your location. If the voltage is different, please contact Wonchang for motor and starter information.

Correct direction of rotation is marked by an arrow on the motor fan housing and is counterclockwise when looking at the motor from the motor's fan side.

***After electrical connections have been made, the rotation of the motor should be checked. If backward, reverse any two leads of the three at the power connection.***

## 1.5 Vacuum Connections

Use a pipe size that is at least the size of the pump inlet connections. Smaller lines result in a reduced pump capacity.

Pumps operating in parallel on a common main line should have a manual or automatic operated shut-off valve or positive action check valve, installed in the suction line adjacent to the pump suction flange. The built-in anti-suck back valve should not be used as a shut-off valve for the vacuum system.

Remove the plastic protective cap from the inlet port prior to connection of pump to the system.

Should process gas contain dust or other foreign particles, a suitable in line (inlet) filter should be connected to the inlet port. Consult Wonchang for recommendations.

The vacuum piping should be designed to ensure that no liquids such a condensate or liquid carried over from the process can reach the pump. If this possibility exists, a knock-out liquid separator should be installed. Consult Wonchang for recommendations.

The following flange sizes are standard on the pumps

<u>Pump Model</u>	<u>Inlet Size</u>	<u>Exhaust Size</u>
VCX 1005	DN 100 PN6	DN100 PN10

## 1.6 Oil Filling on Gear Box

The pump is shipped without oil in gear box. After level installation and correct rotation has been established, fill the pump with recommended gear oil through the oil fill port. Oil level should be over 3/4 position on the oil sight glass as shown on the label.



We recommend ISO VG150 gear oil or equivalent oils:

**Wonvac G150, Shell OMALA S4 GX 150 or Amsoil GEAR LUBE 150 or ANDEROL # 4150**

The following table gives the approximate quantities of oil required for each model.

<u>Pump Model</u>	<u>Capacity (liter)</u>
VCX 1005	2.8

***Do not add fill oil with pump running! Do not overfill.***

## 2.0 SAFETY

Please read the following safety notice carefully before operating the vacuum pump

### 2.1 General Notices

- Understand fully this installation and operating manual before operation.
- The other person except authorized operator should not operate the vacuum pump.
- When the compressor is not properly working, it should be stopped immediately.
- Wonchang shall have no liability for any accident and failure arising from no compliance with instructions in this manual.

### 2.2 Warning labels and its explanation

Following warning labels are shown and attached on VCX series vacuum pump.

#### 2.2.1 Read and Understand a manual:

Read and understand operator's manual before using this machine.

#### 2.2.2 Burn Hazard:

Hot surface. Do not touch.

#### 2.2.3 Loud noise Hazard

Loud noise hazard. Ear protection must be worn.

#### 2.2.4 Hazardous Voltage:

Disconnect power before opening. Contact causes severe electrical shock



### 2.3 Location of the labels

The labels of 2.2.1 Read and Understand a manual, 2.2.2 Burn Hazard, and 2.2.3 Loud noise Hazard

shall be shown on the top of sound shield of the pump.

The label of 2.2.4 Hazardous Voltage shall be shown on the cover of motor's terminal box.

## 3.0 OPERATION

### 3.1 Start-up

Check rotation of the motor as described in paragraph 1.4 Power Requirements.

Fill the pump with oil as described in paragraph 1.5 - Oil Filling

Start the pump with the inlet closed. Run the pump for a few minutes and then shut down. Check the oil level again and make sure the oil level is over 3/4 position of oil sight glass as shown on the label. Add oil though oil fill port, if necessary. Pump oil should only be added when the pump is off

### 3.2 Stopping the pump

To stop the pump, turn off the power. An anti-suck back valve (built-in) for these pumps installed in inlet flange will prevent the air from back flowing into the vacuum chamber after the pump is shutdown.

***Caution: In applications, where the quantity of water vapor is moderate, it is recommended to run the pump for 10 minutes at least with outside air prior to shut down to prevent the vapor from condensing in the pump.***

### 3.3 Operating Conditions

The VCX 1005 is designed to run up to ultimate continuous vacuum levels stated in technical data (6.0) for continuous operation. Operation over maximum vacuum level may result in failure of and severe damage to the machine. Vacuum Regulator installed in inlet side is set at maximum allowable continuous vacuum at factory, and a desired vacuum level to below the maximum level can be achieved by rotating the adjustment screw.

The standard version is for use of dry air only, and may not be used in hazardous areas. Handling of humid air or gases containing aggressive chemicals is possible only with specially configured units. Consult Wonchang for assistance.

Excessive back pressure on the unit may result in excessive current draw. Do not operate the vacuum pump over 0.15 kg/cm<sup>2</sup> back pressure

Also it is recommended for operating personnel who is working near the pump to wear ear protectors. If noise below the designed dBA is required, an external sound enclosure can be added to the system, provided adequate ventilation is provided

The ambient and suction air temperature must be between 5 and 40 °C deg

***Caution: Any non compliance may lead to severe injury to persons and damage to the pump.***

***Caution: Maximum number of motor starts per hour should not exceed 10 per hour. Excessive starting of the motor can cause overheating and premature failure of the motor and coupling. A minimum run timer should be used with nay panel that may control the pump with automatic starts and stops based on system pressures.***

## 4.0 MAINTENANCE

VCX-Series vacuum pumps require very little maintenance. To ensure optimum performance, the following maintenance steps should be followed:

### 4.1 Gear Box Lube Oil

#### 4.1.1 Oil Level

Check the oil level on monthly basis. Under normal circumstances it should not be necessary to add oil between oil changes. A significant drop in oil level means there is an oil leak. Please check the o-rings, drain plug or oil sight glass.

Check the oil level only when the pump is shut off. Replenish oil if it drops below bottom position of the sight glass.

***Caution: Do not add oil while the pump is running, since hot oil can escape from the oil fill port.***

#### 4.1.2 Oil Type and Quantity

See section 1.5 - Oil Filling - for details on oil type and quantity

#### 4.1.3 Oil Change

Under normal ambient conditions with proper Gear Oil, it is recommended to change the oil every 10,000 operating hours. It is necessary to make the first oil change between 500 ~1000 operating hours..

***Caution: If different brand oil is being filled, the old oil must be drained completely from the gear box.***



## 4.2 Maintenance Chart

**Weekly:** Check inline inlet filter element / Mesh.  
More often if high particulates in inlet stream

**Monthly:** Check the oil level, Protective Mesh.

**Bi-Monthly:** Check fans and coupling

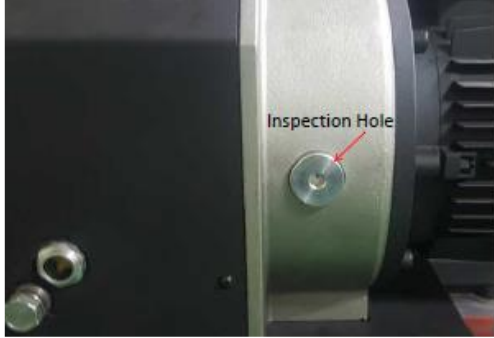

Inspection hole with G1" plug: Check the coupling and fan through this hole regularly.  
(The endoscope(WireCam) can be used with Smart Phone software)

**Annually:** Check Bearings / Shaft Seals /Vacuum regulator  
More frequently if operated at ambient temperature exceeding 20°C.

**Every 5,000 ~10,000 operating hours:** Check the gear oil conditions, and if necessary,  
change the oils.

## 5.0 PROBLEM SOLVING

### 5.1 Problem

The pump does not reach capacity.

#### 5.1.1 Possible Cause

Inlet screen (mesh) of the inlet filter clogged with debris.

*Remedy* : check inlet filter element and clean screen (mesh) by compressed air or wash it.

#### 5.1.2 Possible Cause

Pipe work is too long or small.

*Remedy* : Use the bigger diameter pipe and shorten the lines length if possible.

### 5.2 Problem

The pump runs over set pressure.

#### 5.2.1 Possible Cause

Inlet screen (mesh) in the vacuum regulator clogged with debris.

*Remedy* : clean screen (mesh) and check inlet filter element.

#### 5.2.2 Possible Cause

Vacuum regulator set over the set point or is out of order.

*Remedy* : Set the point again or replace it with new one.

### **5.3 Problem**

Vacuum pump does not reach the set pressure.

#### **5.3.1 Possible Cause**

Leak on the pump or system.

*Remedy* : Check the leak on the pump or system.

### **5.4 Problem**

The pump runs very noisy.

#### **5.4.1 Possible cause**

Contamination of the claws or chamber.

*Remedy* : Clean the pumping chamber and the claws.

#### **5.4.2 Possible cause**

Coupling insert is worn.

*Remedy* : Replace coupling insert in motor/ pump coupling.

#### **5.4.3 Possible Cause**

Bearing noise

*Remedy* : Replace bearings or call service agent for service or exchange program.

#### **5.4.4 Possible Cause**

Vacuum regulator noise

*Remedy* : Replace Vacuum regulator

### **5.5 Problem**

The pump will not start.

#### **5.5.1 Possible Cause**

Supply voltage is not proper or is overloaded. Motor starter overload settings are too low or improper; fuses are burned; wire size is too small or too long causing a voltage drop.

*Remedy* : check voltage supply; overload settings in motor starter for size and settings according to motor nameplate. Install proper size wire. If ambient temperature is high, use the next larger size overloads, or adjust settings 5% above motor nameplate value.

*Remedy*. Repair or replace if needed or call service agent for service or exchange program.

### **5.6 Problem**

The pump is running too hot abnormally.

#### **5.6.1 Possible Cause**

Not enough air ventilation to pump.

*Remedy* : Make certain a sufficient amount of fresh air is supplied to the pump.

## 5.7 Problem

The pump will not operate (seized up).

### 5.7.1 Possible cause

Rotary Claws, Bearings or Gears stuck on..

*Remedy* : Call service agent for service or exchange program

## 6.0 TECHNICAL DATA

Specification : Vacuum Application

Model		VCX 1005
M3 / Hour (cfm)	60Hz	1140 (670cfm)
	50Hz	950 (558cfm)
Ultimate Va. Max.	Torr	37.5 (50mbar a)
Ultimate Va. Continuous	Torr	150(200mbar a)
Kw(Hp)	60Hz	22 (30Hp)
	50Hz	18.5 (25Hp)
RPM	60/50Hz	3540/2945
Voltage Available		220~240/380~420V x 50/60Hz, 400/690V x 50Hz, 208~230/460V x 60Hz
dB(A), Max +- 3 tolerance	60Hz	85
	50Hz	82
Oil Capacity (Gear box)	Ltr	2.8
Inlet / Outlet Connection	Flange	DN 100 PN6 / DN100 PN10
Amb. Operating Temp.	(°C)	5~40
Pump Weight (w/o motor)	Kg	~ 586
Accessories(option)	Non Return Valve, Vacuum Regulator, Exhaust Silencer, Inlet filter 4" flanged	

### 6.1 Options:

**6.1.1** Gas tight version is available. Ventilation holes between gearbox and pumping chamber on pump module is piped to inlet port side using stainless steel tubes and fittings. Vacuum regulator is removed in this version.

**6.1.2** Aqua version is available. Aqua version is composed of PEAK coating on internal parts of pumping chamber, end plates, cylinder, rotors, and drain valve and pipe (position # 118 and 119) on silencer. Also Drain pipe and valve is installed on the silencer.



Acquisition of Certification



# WONVAC

WONCHANG VACUUM

